

ASSEMBLY MANUAL REVA3

ML4054B Adapter Change

Table of Contents

Fan Fixture Removal	2
Thumb Screw Removal	3
Cable's Case Removal	4
Knurled Screw Removal	5
Adapter Removal	6
Install Adapter and Components	7
MultiLane	8



STEP 1

* Fan Fixture Removal *

DETAIL D
SCALE 2 : 1

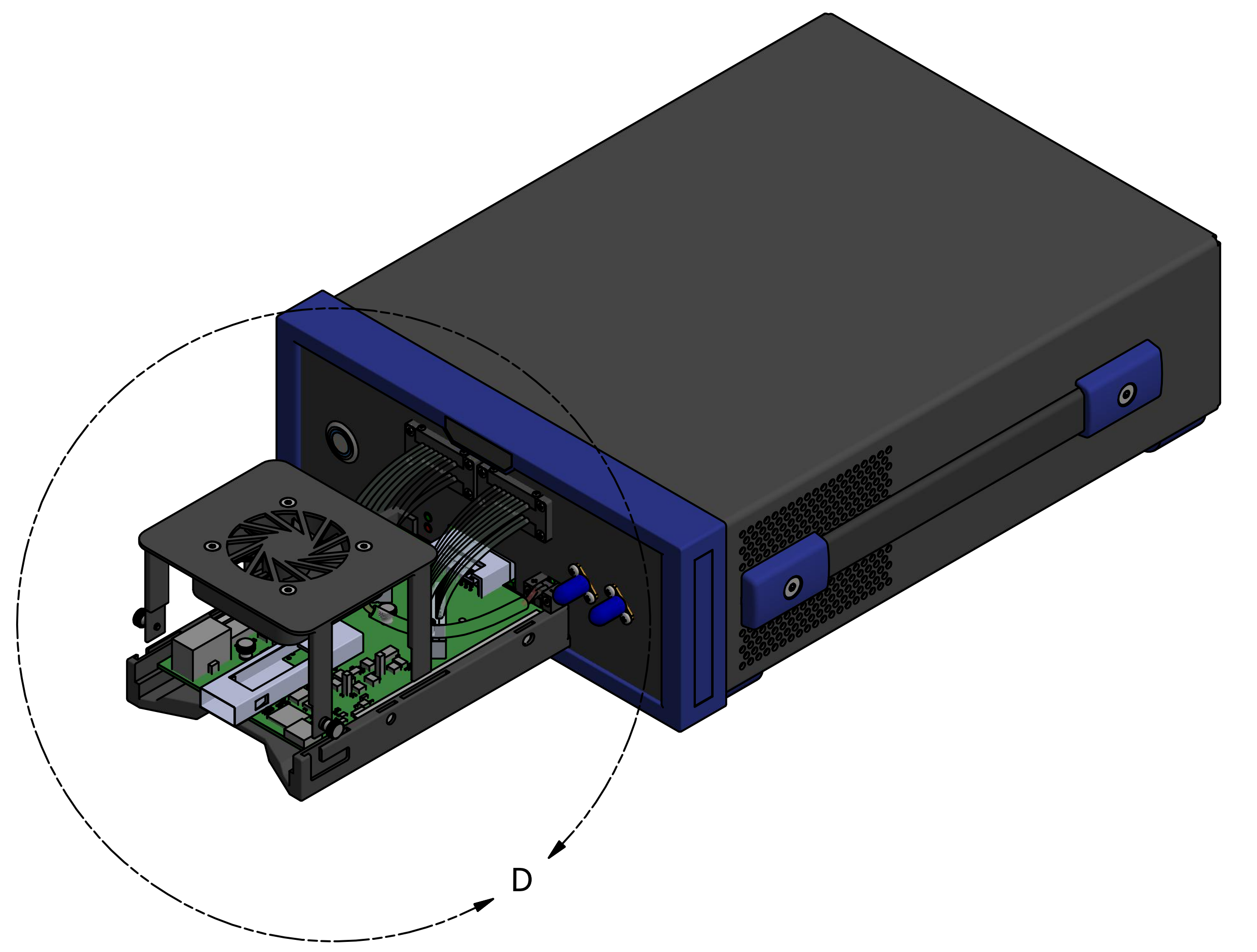
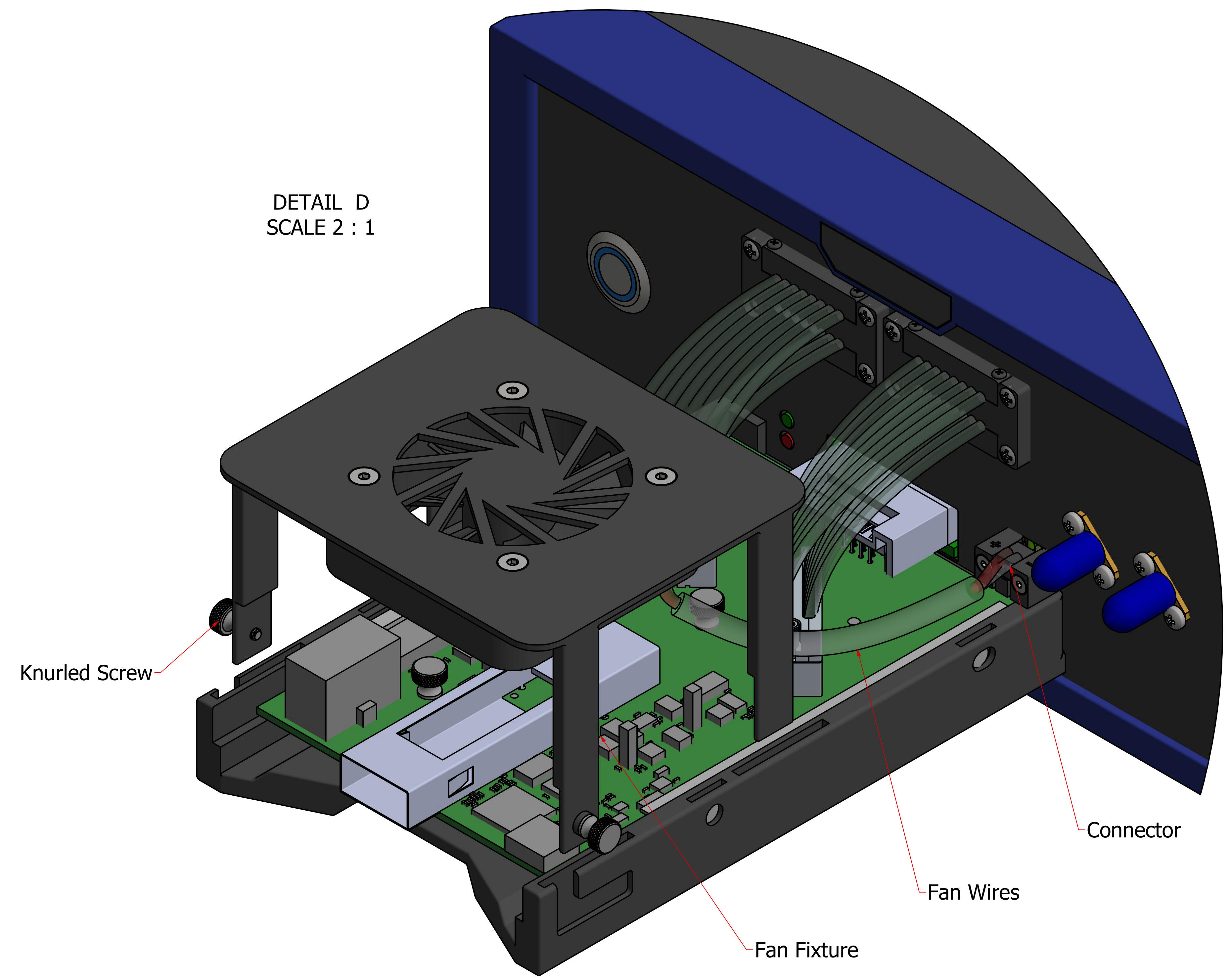

- Unplug Fan Wires Connector
- Untighten the Knurled Screws (Qty:2)
- Hold Fan Fixture well and remove it from the T-Slot guides

STEP 2

* Thumb Screw Removal *

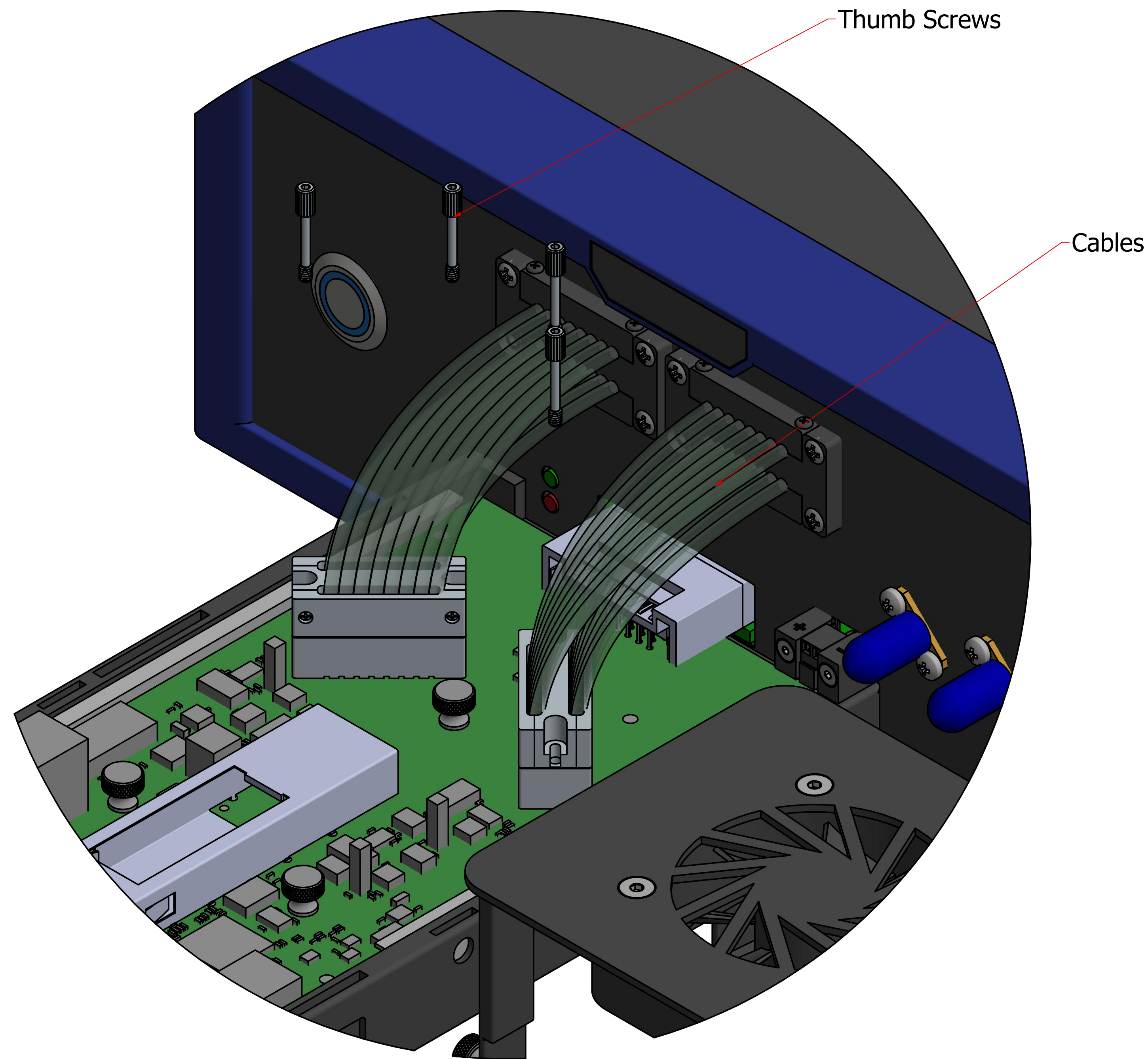

DETAIL F
SCALE 2

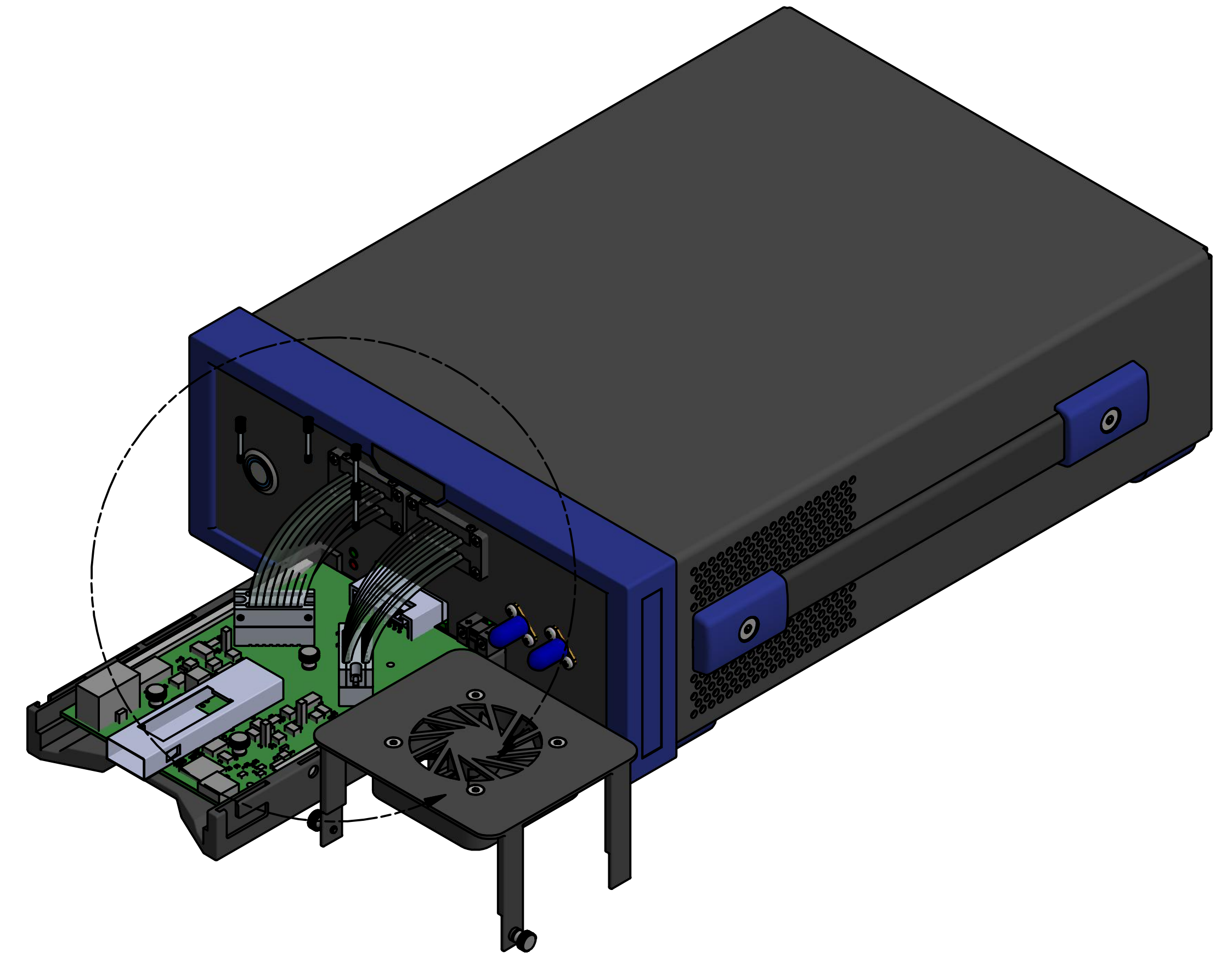

- Hold the Cables well without applying force on them to prevent damaging the spring inside each cable
- Carefully untighten the Thumb Screws (Qty:4) using a 0.05" hex key

Note: When tightening / untightening thumber screw, DO NOT fully tight / untight one screw and then the other. Tighten / Untighten each screw a bit, several times, to prevent cable's case from twisting which leads to spring damage.

STEP 3

* Cable's Case Removal *

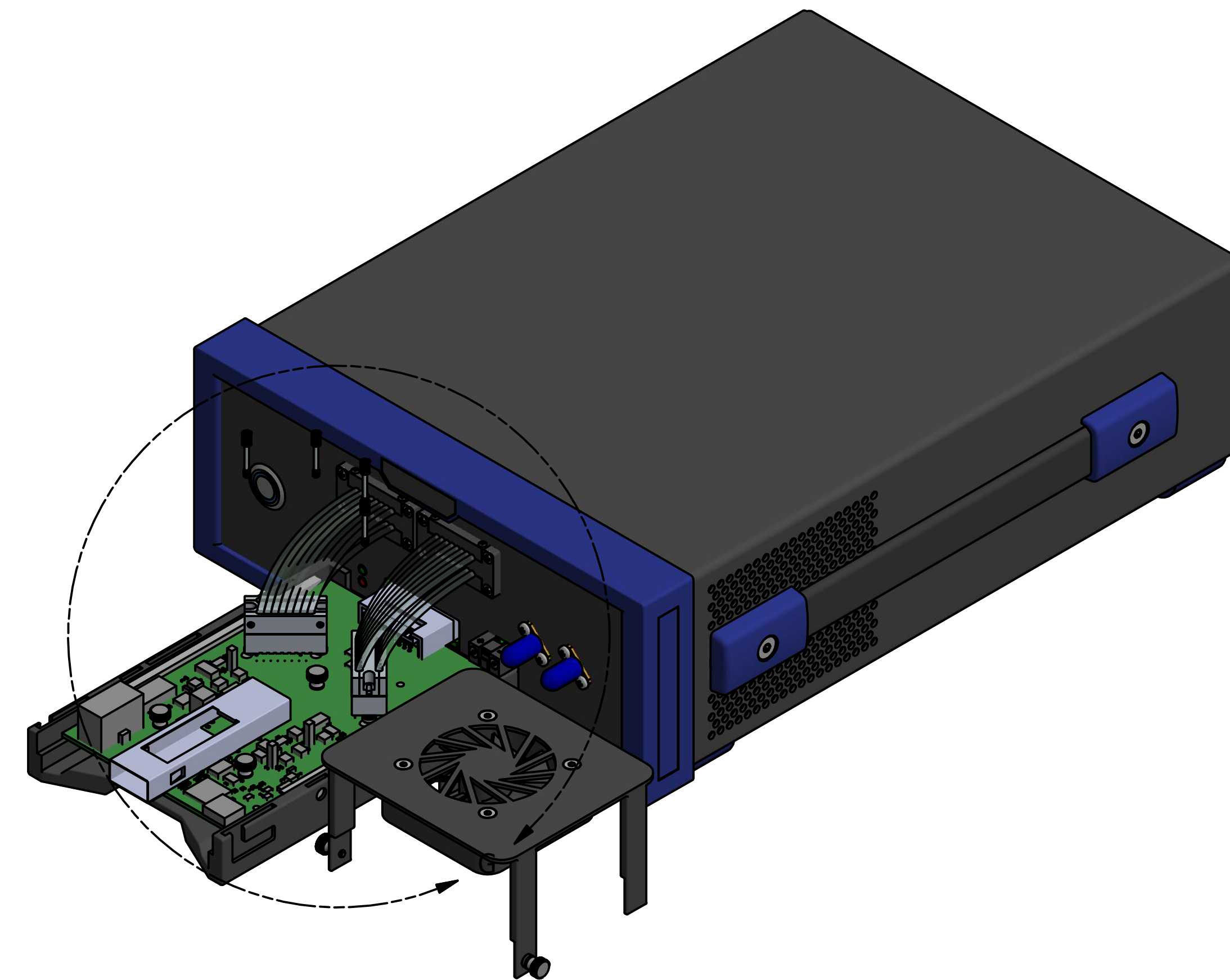
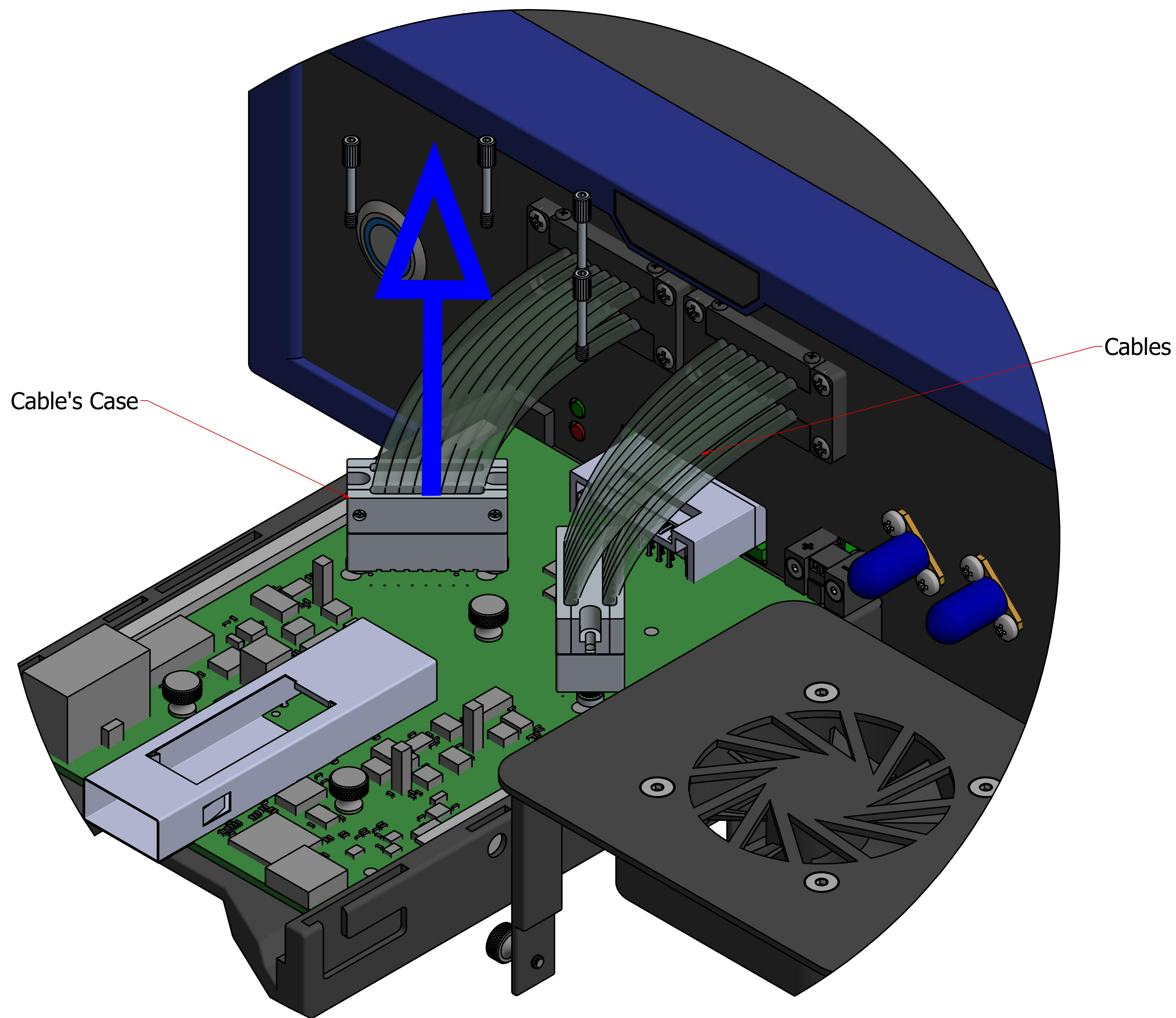

Hold the cables well, and carefully pull the Cable's Case VERTICALLY from the PCB

DETAIL G
SCALE 2

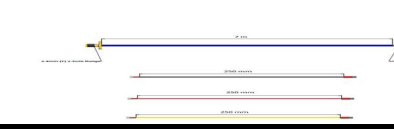

STEP 4

* Knurled Screw Removal *

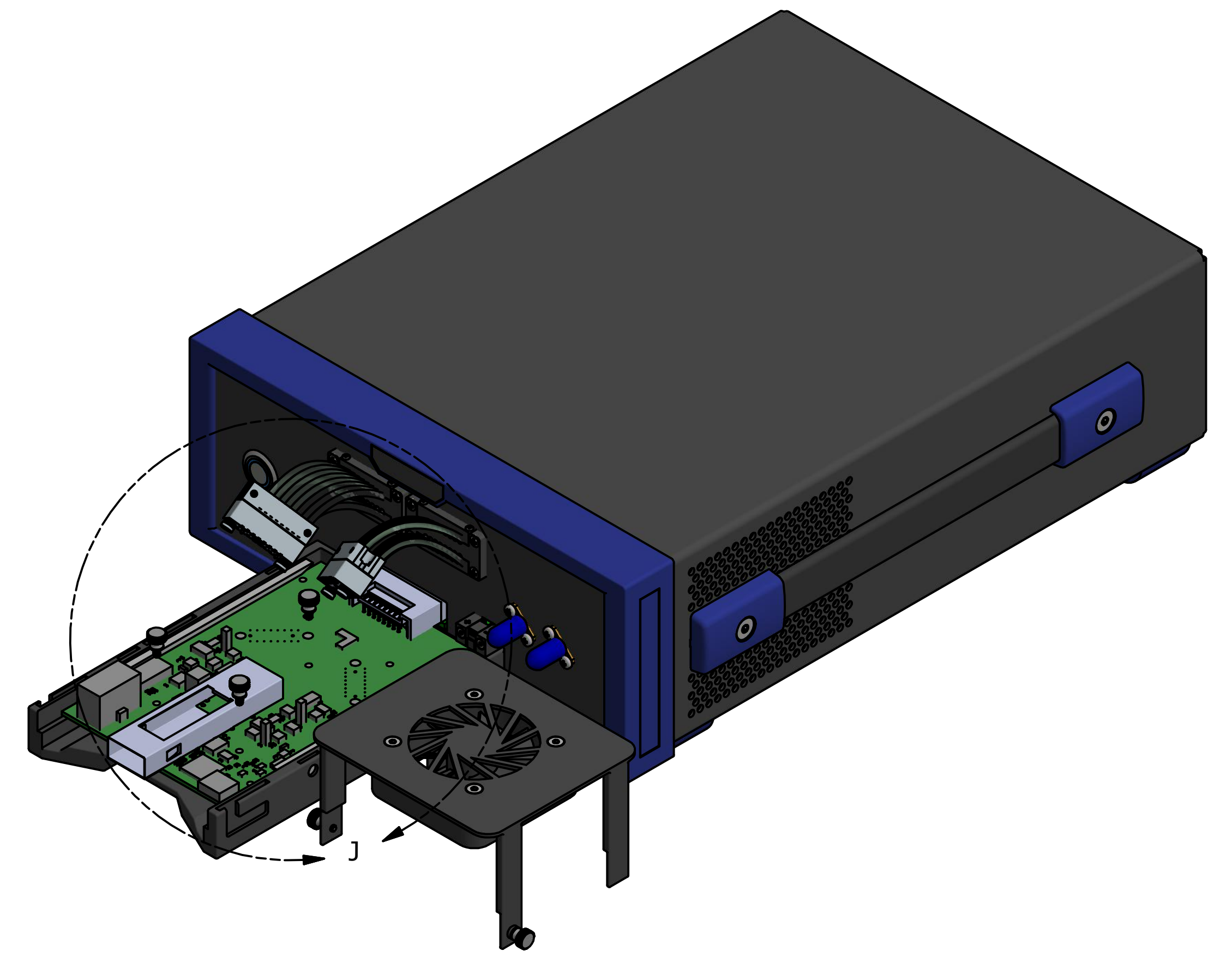
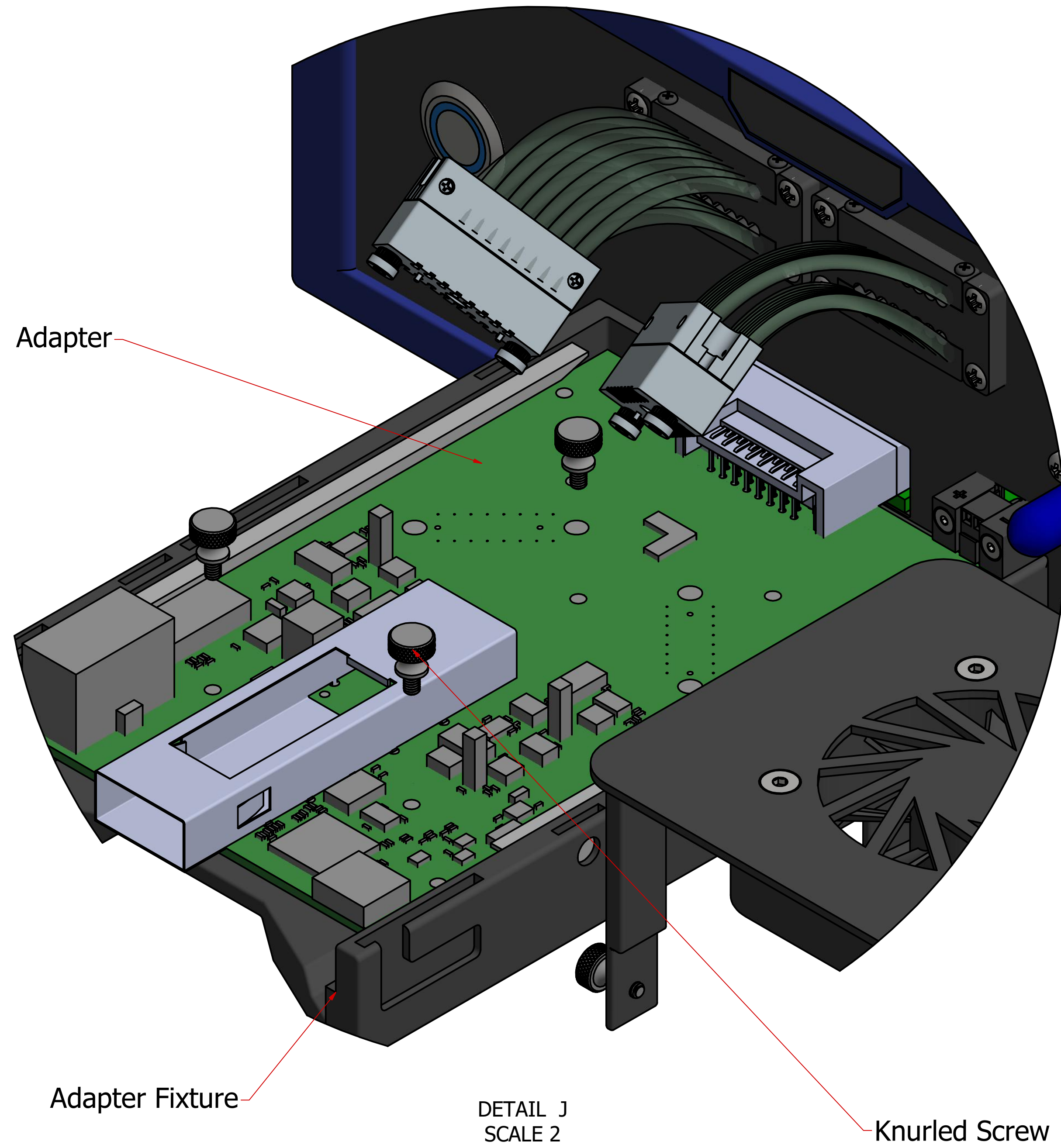

Untight the Knurled Screws (Qty:3) which fix the Adpater to the Adapter Fixture

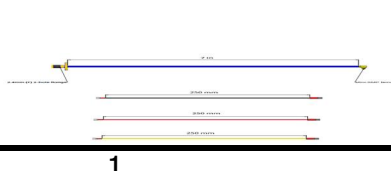

STEP 5

* Adapter Removal *

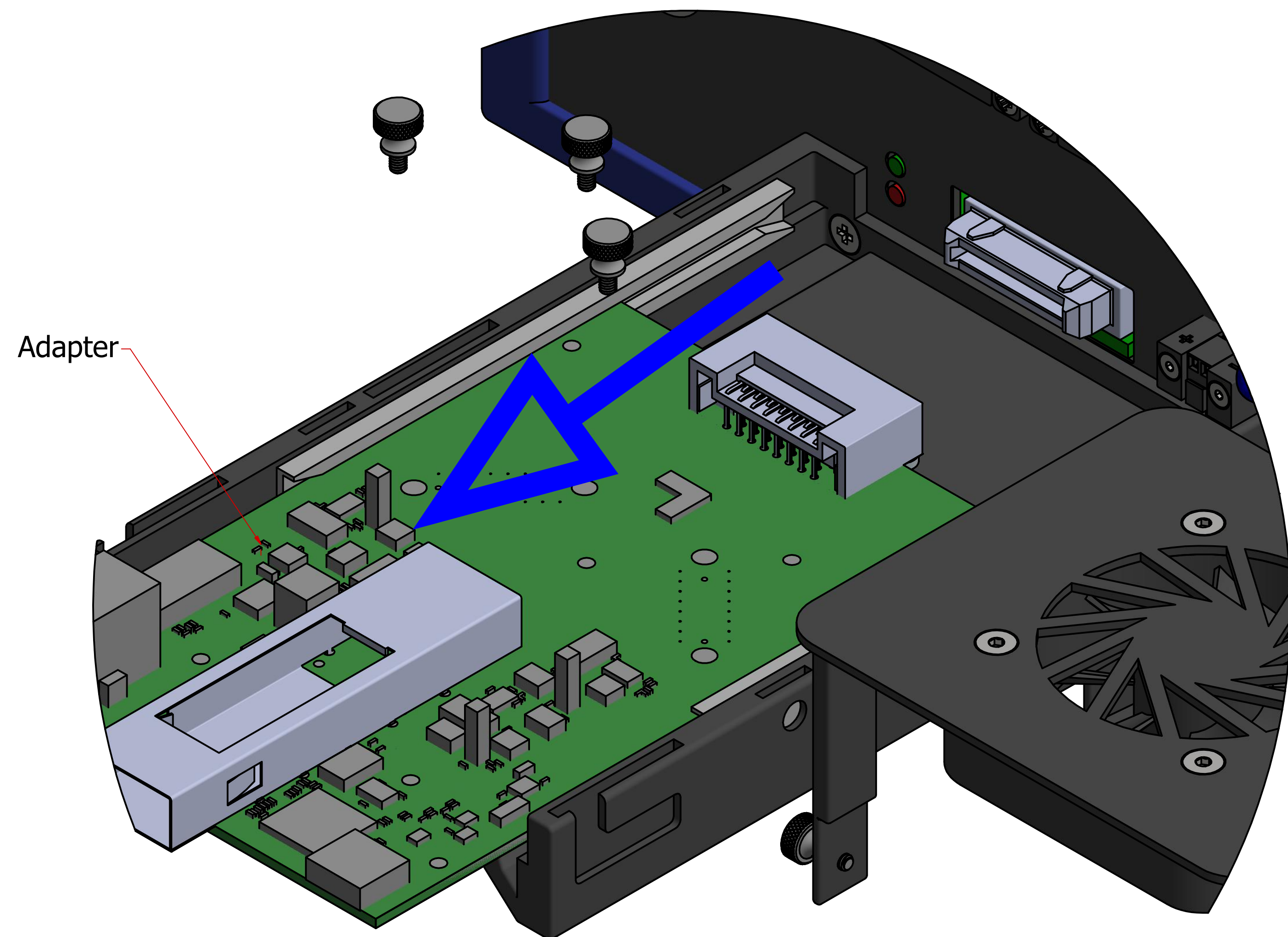

Adapter

DETAIL H
SCALE 2

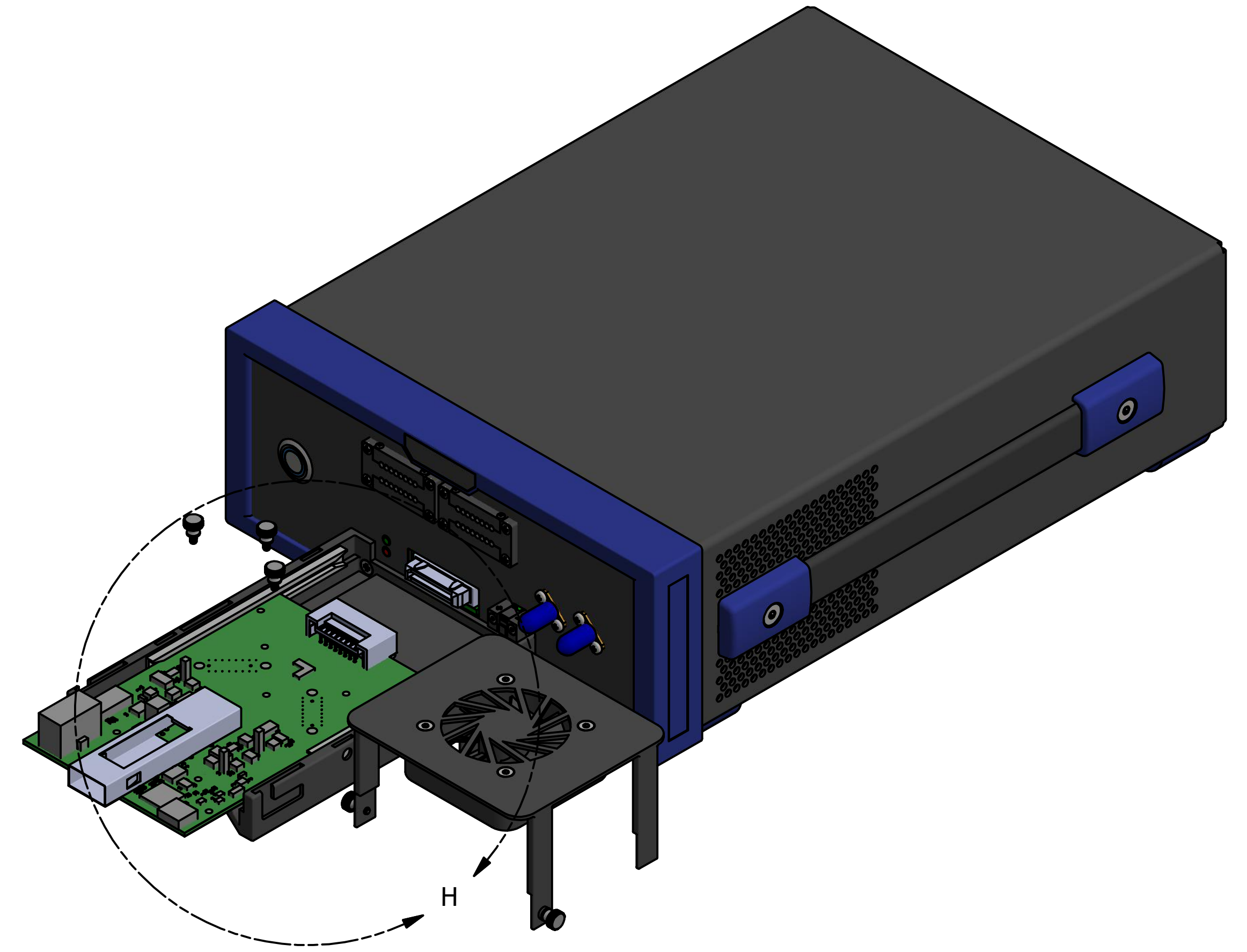

Hold the adapter well and pull it **HORIZONTALLY**
from the connector in the instrument

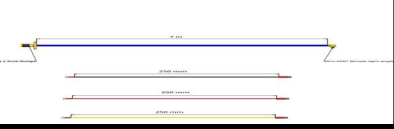

STEP 6

* Install Adapter and Components *

Repeat the same steps but in reverse direction:

Install and fix Adapter:

- Insert the required Adapter HORIZONTALLY in the Connector
- Tighten the three Knurled Screws to fix the Adapter to Adapter Fixture

Install and fix Cable's Case:

- Place the Cable's Case VERTICALLY to the new installed Adapter. Pay attention to align two Dowel Pins on the Cable's Case and the two Guide Holes on the Adapter
- Tighten the four Thumb Screws

Install and fix Fan Fixture:

- Place the Fan Fixture into the T-Slot linear guide
- Install the Fan Wires in the Connector

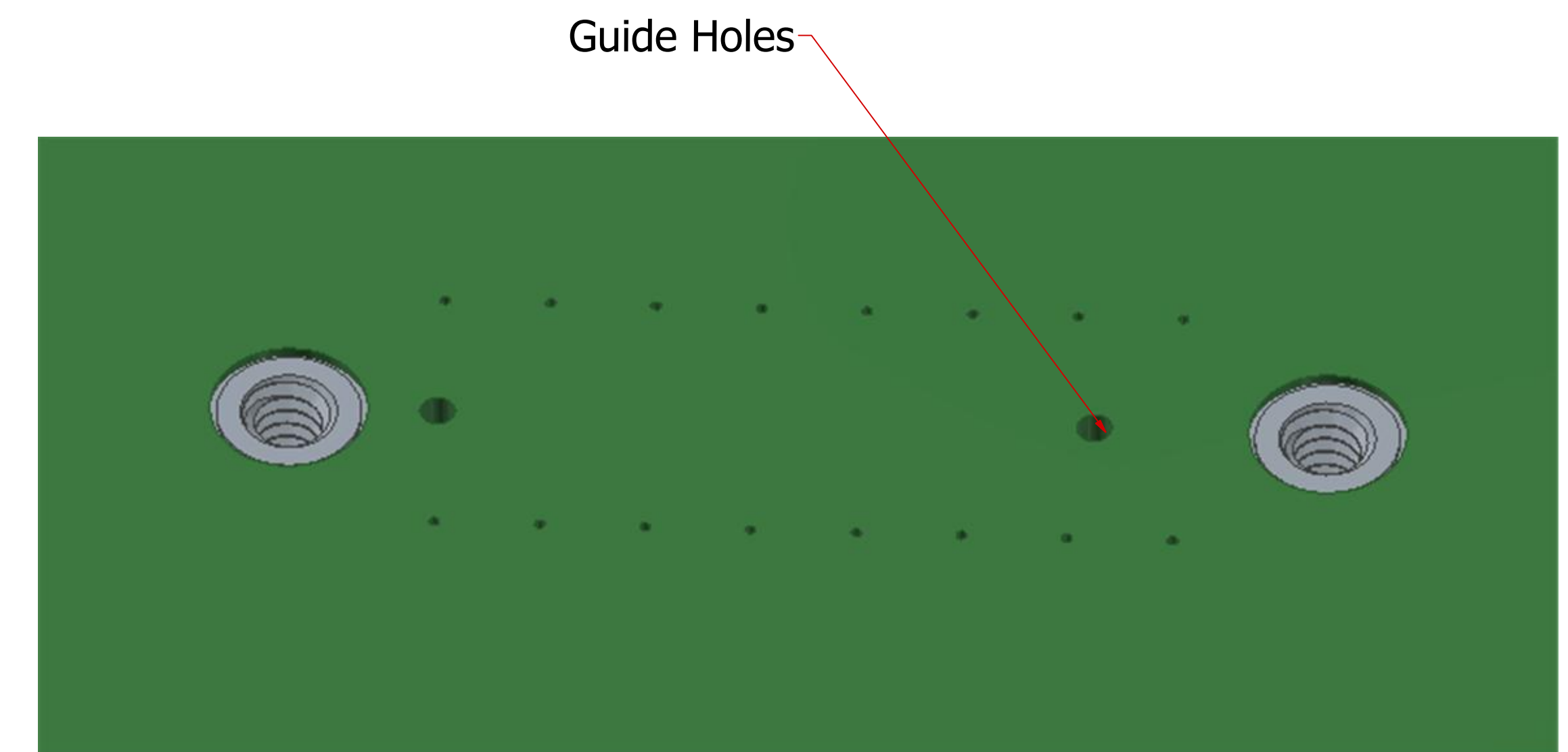
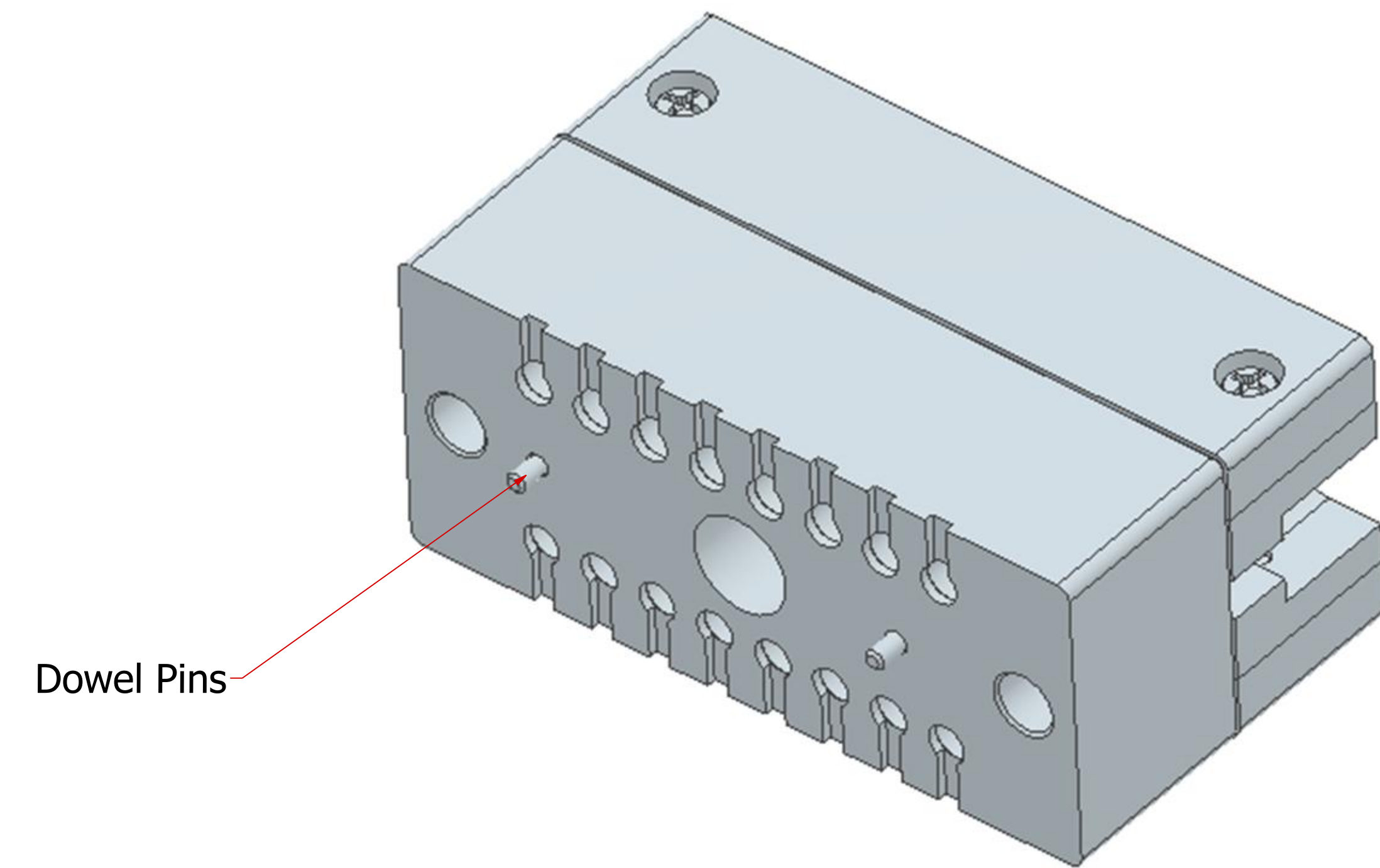

multiLane

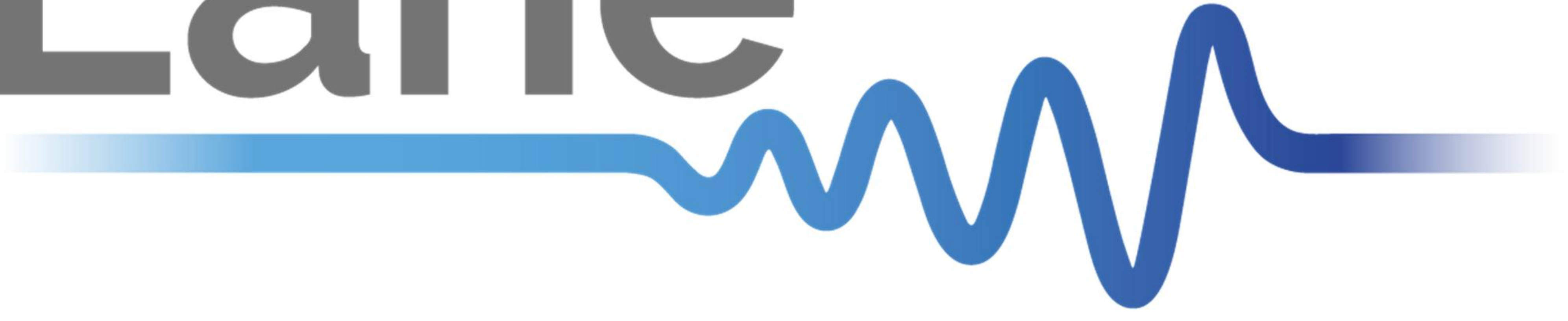

Innovation for the next generation

www.multilaneinc.com